

GENERATION 1 : OPERATION SUMMARY

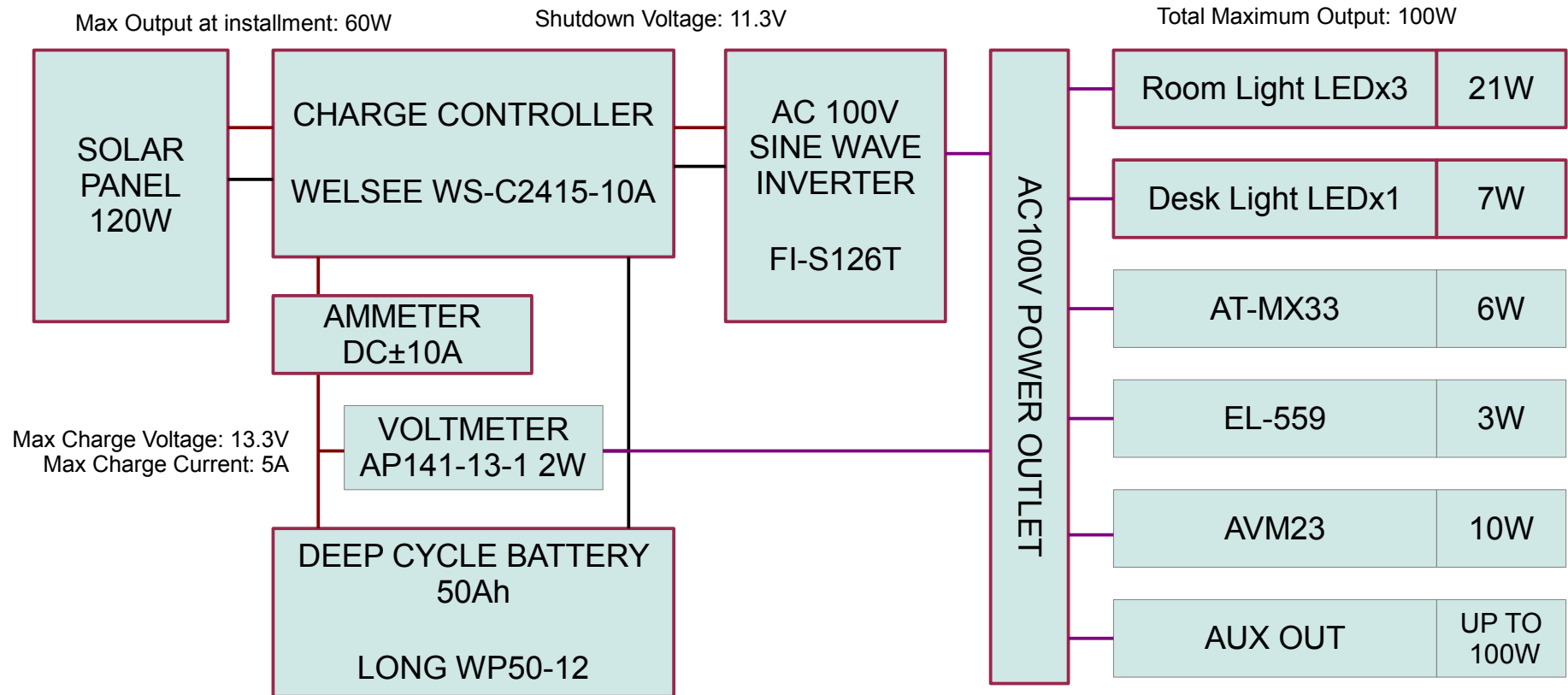

Economical View

- April 2011 to December 2012: Operated for 20 months
- Total BOM cost (for the boxes shown in red frame) : approx. 98,000 JPY
- Estimated Total Utilized Power: 76.8kWh (32W x 4h x 600 days)
- Amortized Cost per kWh: 1,360 JPY

Technological View

- Vertical installation of the solar panel limited the max output
- Simple PWM charge strategy and too low charge voltage setting limited the charge capacity
- Battery capacity not enough in case of three consecutive non-sunny days